

**HAYMAN REESE**

**PART No: 03006W**

**HOLDEN VE OMEGA, BERLINA, CALIAS, SV6&SS 08/10 ON**

## INSTALLATION INSTRUCTIONS

PLEASE ENSURE THAT ALL INSTRUCTIONS ARE UNDERSTOOD PRIOR TO FITMENT  
PLACE THESE INSTRUCTIONS IN THE VEHICLE'S GLOVEBOX AFTER INSTALLATION IS COMPLETED



Installation Time: Approx **50** Mins

**Towbar Installation Instructions**

**Towbar capacity**

**HOLDEN VE OMEGA, BERLINA, CALIAS, SV6&SS 08/10 ON**

**Part Number 03006W**

**Max Towing Braked 1250 kg**

**Max Towing Unbraked 75 kg**

**Max Static Ball Load 125 kg**

Hayman Reese (Cequent)  
PO Box 4050, Dandenong South VIC 3164  
Phone 1800 812 017 Email [info@haymanreese.com.au](mailto:info@haymanreese.com.au)

# HAYMAN REESE

PART No: 03006W

HOLDEN VE OMEGA, BERLINA, CALIAS, SV6&SS 08/10 ON

## INSTALLATION INSTRUCTIONS

PLEASE ENSURE THAT ALL INSTRUCTIONS ARE UNDERSTOOD PRIOR TO FITMENT  
PLACE THESE INSTRUCTIONS IN THE VEHICLES'S GLOVEBOX AFTER INSTALLATION IS COMPLETED

### Warning:

1. Do not, drill, cut, weld or otherwise modify the towbar.
2. If you are using electric welding on a motor vehicle, **always** check that the vehicle is not equipped with electronic engine or instrument management equipment. Failure to do so could **destroy** any onboard computers. If in doubt, check with the vehicle's manufacturer.

### General:

1. Ensure all hardware items have been included refer to assembly diagram.
2. It is recommended that the instructions are read through and completely understood before making any attempt to fit this product.
3. Be wary of any changes to vehicle designs or other accessories that may conflict with the installation of this product.
4. Before drilling ensure that the area is clear of fuel, electrical & other components.
5. All holes drilled into the body panels shall have all burrs & swarf removed then coated with a suitable rust preventative paint.
6. The high tensile fasteners supplied with this product were used to achieve the specified rating. If replacement is required ensure that fasteners of the same rating & quality are used. Contact an authorised **Hayman Reese** dealer if further information is required.
7. Ensure that all hardware is fastened to torque list below check fasteners on regular basis.
8. Towbar load rating sticker provided with this product shall be conspicuously located on inside rear end of the driver's door. **(See diagram below)**.
9. Hayman Reese recommends that you check your tow ball to ensure that it complies with the Australian standards **AS 4177.2**.
10. **PLEASE NOTE:** It is advised to remove your LUG or TBM when not actually towing so as to produce a clear view of the vehicles registration plate if obscured, and to also provide maximum available departure angle.
11. Pull Pin must be fit in down position.

### Tow bar Maintenance and Care.

Hayman Reese recommends that bolt torque's, as listed below, are routinely and regularly inspected and checked for correct tension. Replace any worn or defective parts.

We recommended to remove Tow Ball Mounts (TBM's, tongues or lugs) when not being used for any considerable length of time.

So as to avoid injury, when not towing it is suggested that the tongue, Pull Pin and R-clip are removed then stored in a safe, clean and dry place, away from excessive moisture.

Hitch Pull Pins and spring "R" clips are regularly checked for proper installation. Replace any worn or defective parts.

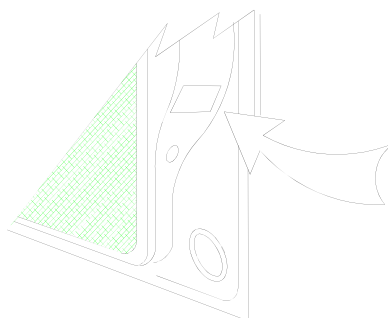

Place load rating sticker  
inside driver's door here

### RECOMMENDED ASSEMBLY TORQUE LISTING

#### Diameter Grade 8.8 Bolt

M6	9.5 Nm
M8	21.7 Nm
M10	43.4 Nm
M12	77.3 Nm
M14	146 Nm
M16	189.8 Nm

### FOR TOWING PURPOSES ONLY

For towing capacity details please refer to vehicle owner's manual or to the manufacturer. Overloading can void your warranties.

# HAYMAN REESE

PART No: 03006W

HOLDEN VE OMEGA, BERLINA, CALIAS, SV6&SS 08/10 ON

## INSTALLATION INSTRUCTIONS

PLEASE ENSURE THAT ALL INSTRUCTIONS ARE UNDERSTOOD PRIOR TO FITMENT  
PLACE THESE INSTRUCTIONS IN THE VEHICLES'S GLOVEBOX AFTER INSTALLATION IS COMPLETED

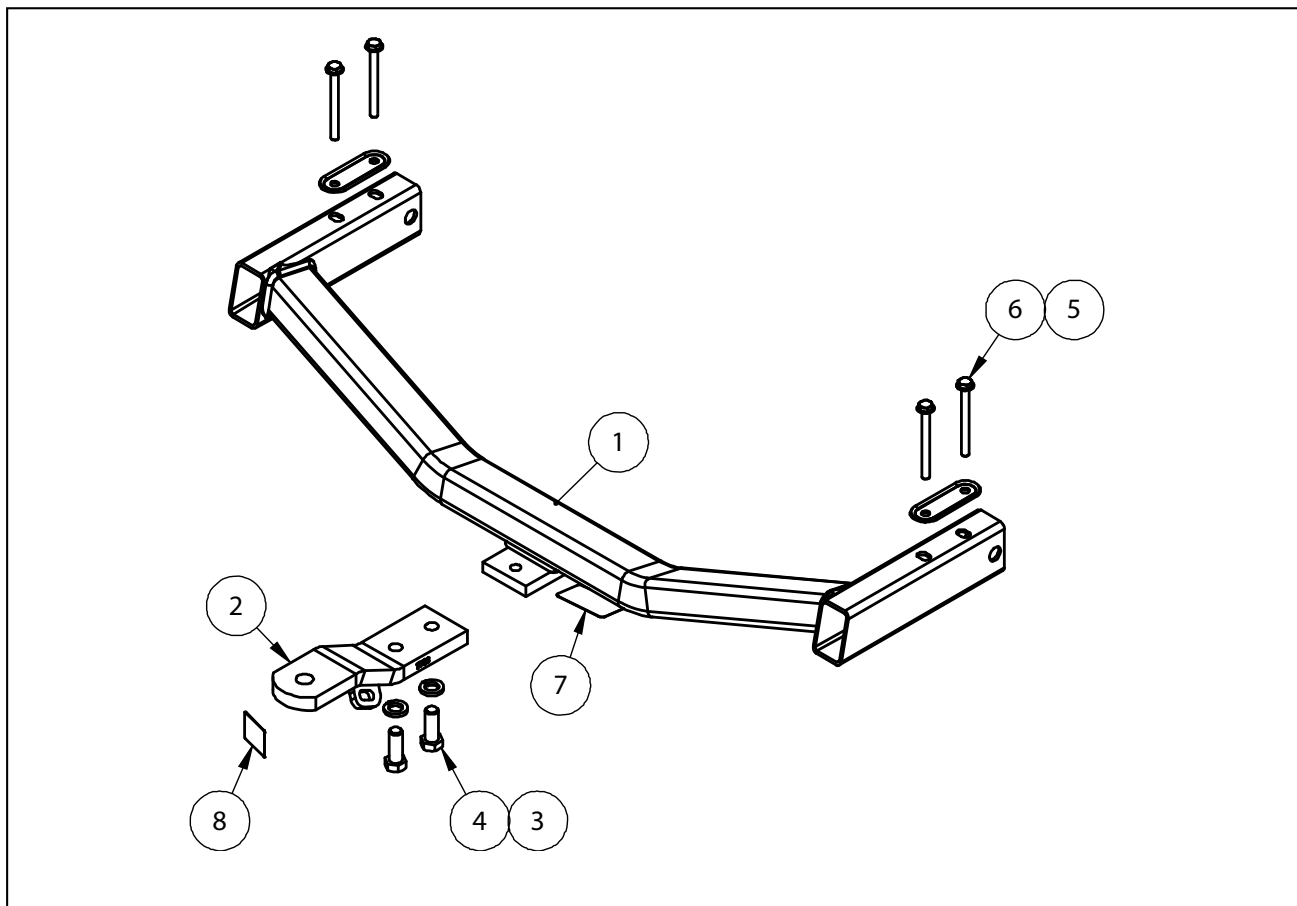

QTY	DESCRIPTION	ITEM NO
1	HOLDEN VE WELDED ASSY	1
1	ASSEMBLY LUG	2
2	M16x5x3.5 SPRING WASHER	3
2	M16x45 2.0P BOLT	4
2	FORMED BOOT PLATE	5
4	BOLT SP. M10x1.5x1.5P (11589345)	6
1	ACRYLIC CP LABEL	7
1	H.R STICKER	8

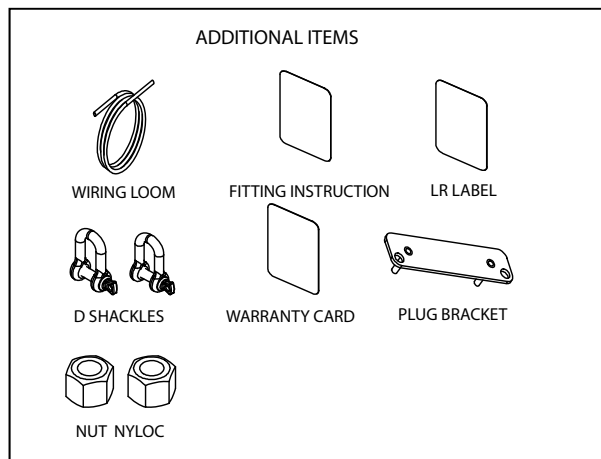

## HAYMAN REESE

PART No: 03006W

HOLDEN VE OMEGA, BERLINA, CALIAS, SV6&SS 08/10 ON

### INSTALLATION INSTRUCTIONS

PLEASE ENSURE THAT ALL INSTRUCTIONS ARE UNDERSTOOD PRIOR TO FITMENT  
PLACE THESE INSTRUCTIONS IN THE VEHICLES'S GLOVEBOX AFTER INSTALLATION IS COMPLETED

#### Rear Luggage Compartment & Reverse Sensor if fitted

1. Open the Rear Luggage Compartment then remove the spare wheel cover.
2. Remove the Rear Plastic Trim via.
  - a. 4 Plastic Trim Buttons 2 each side.
  - b. Then pull in an upwards motion to remove.
3. Remove the left hand side Trim Panel via.
  - a. 2x Plastic Trim Plugs
  - b. Tabbed Tongue on the top edge of the trim being careful not to tear.
  - c. Pull trim to the side. Repeat for other side.
4. Disconnect the Rear Parking Sensors connector if fitted , and then pull through existing hole in Trim

## HAYMAN REESE

PART No: 03006W

HOLDEN VE OMEGA, BERLINA, CALIAS, SV6&SS 08/10 ON

### INSTALLATION INSTRUCTIONS

PLEASE ENSURE THAT ALL INSTRUCTIONS ARE UNDERSTOOD PRIOR TO FITMENT

PLACE THESE INSTRUCTIONS IN THE VEHICLES'S GLOVEBOX AFTER INSTALLATION IS COMPLETED

#### Rear Bumper Bar Skin & Impact Beam removal

5. Remove the Rear Bumper Skin Via.
  - a. 2 Plastic Scrivets & 1 Screw from inside the Wheel arch each side.
  - b. 3 Plastic Trim buttons from the underside of the Bumper Bar skin.
  - c. Flex out the bar skin from the sides then pull rearward to remove.
  - d. Place Bumper in a secure location to prevent damage.
  - e. Remove the Impact Beam via 4xM8 Nuts 2 each side.
  - f. Pull the Impact Beam rearward to remove and retain the Beam and M8 Nuts.

**INSTALLATION INSTRUCTIONS**

PLEASE ENSURE THAT ALL INSTRUCTIONS ARE UNDERSTOOD PRIOR TO FITMENT

PLACE THESE INSTRUCTIONS IN THE VEHICLES'S GLOVEBOX AFTER INSTALLATION IS COMPLETED

**Removal of Impact Beam Mounting Brackets**

6. Remove the Impact Beam Mounts Via.
  - a. 4xM10 Bolts from the inside the Rear Luggage compartment as shown.
  - b. Pull rearward to remove left &right Impact Beam mount then discard mounts as shown in the picture.

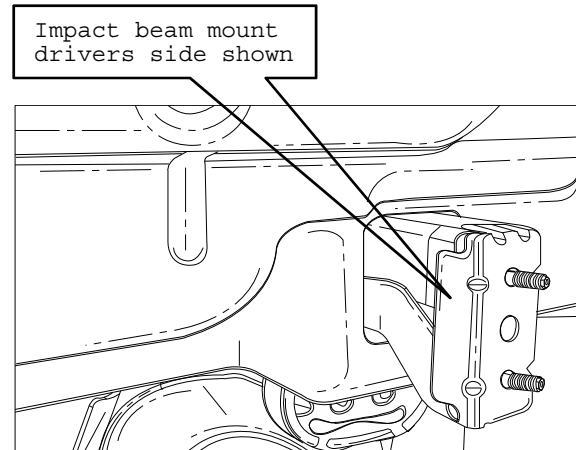
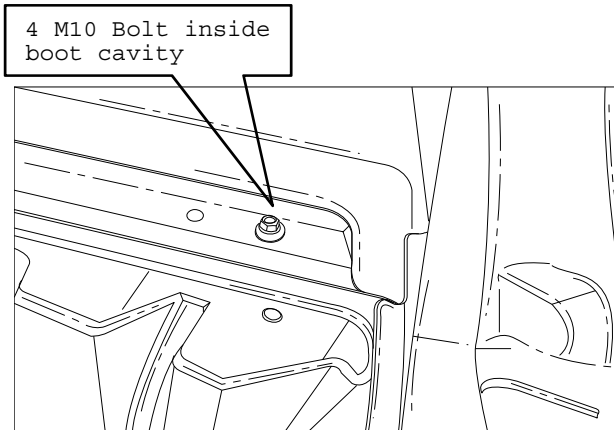

**Fitment of Towbar to Chassis Rails**

7. Offer Towbar to Chassis Rails to align the Towbar mounting arms holes with the existing Chassis holes.
8. Some force may be required to slide the bar up the Chassis Rails.
9. Fit top loose plates with the M10x105 Bolts inside Boot Cavity as shown in the picture.
10. Tighten all Bolts to torque specifications provided on Page 2.

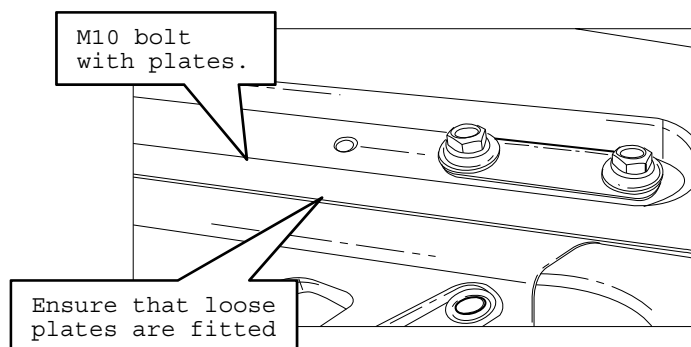

## HAYMAN REESE

PART No: 03006W

HOLDEN VE OMEGA, BERLINA, CALIAS, SV6&SS 08/10 ON

### INSTALLATION INSTRUCTIONS

PLEASE ENSURE THAT ALL INSTRUCTIONS ARE UNDERSTOOD PRIOR TO FITMENT

PLACE THESE INSTRUCTIONS IN THE VEHICLES'S GLOVEBOX AFTER INSTALLATION IS COMPLETED

#### Cut Rear Bumper Skin

11. Using a small pilot drill to pierce through the Bar skin to allow a small blade from a saw or similar device, Cut around the outline of the Holden factory indent in the Rear Bar skin as shown.

Clean all raw edges with a small file to ensure the neatness of the finished cut.

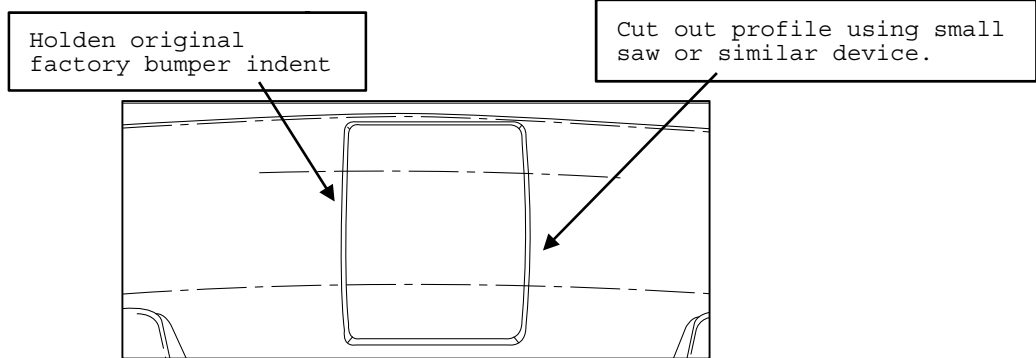

#### Refit the Rear Bumper Bar Skin

12. **Note:** Before installing the Plastic Trim Buttons to the underside of the Bumper Bar Skin, fit the lug to the Towbar by flexing the Bumper Bar skin towards the ground to allow access to the forward most M16 Bolt.

13. Refit the Bumper in the reverse of Steps 5d to 5a.

#### Refit the Rear Luggage Compartment & Reverse Sensors if fitted

14. Refit the trim on the inside of the Rear Luggage Compartment and Sensors if fitted in reverse Step 4 through to Step 1.

**HAYMAN REESE**  
**PART No: 100007-WL**  
**HOLDEN VE/WM COMMODORE SEDAN & WAGON**  
**INSTALLATION INSTRUCTIONS**

PLEASE ENSURE THAT INSTRUCTIONS ARE UNDERSTOOD PRIOR TO FITMENT

**Wiring Loom Installation Instructions**

**HOLDEN VE/WM COMMODORE SEDAN & WAGON**  
**Part No: 100007-WL**

**ECU Required: 04826**  
**Tail Harness Length Required: 1800mm**

**RPA Override Switch Part No: 04848**  
**(If Aftermarket RPA's Fitted)**

**SEDAN – Pages 2-5**  
**WAGON – Pages 7-11**

**Wiring Loom Installation Time: Approx 30 Mins**

Issue Date 23-05-2011

Page 1

Part No: 100007-WL

Hayman Reese (Cequent)  
PO Box 4050, Dandenong South VIC 3164  
Phone 1800 812 017 Email [info@haymanreese.com.au](mailto:info@haymanreese.com.au)

[www.haymanreese.com.au](http://www.haymanreese.com.au)





**HAYMAN REESE**  
**PART No: 100007-WL**  
**HOLDEN VE/WM COMMODORE SEDAN & WAGON**  
**INSTALLATION INSTRUCTIONS**

PLEASE ENSURE THAT INSTRUCTIONS ARE UNDERSTOOD PRIOR TO FITMENT

This section is for Sedan vehicles only.  
For Wagon vehicles please refer to Page 6.

1. In the luggage compartment remove the floor carpet (1).



2. Remove the luggage compartment rear trim (1) by removing the cargo strap hooks and the two lower clips (2).

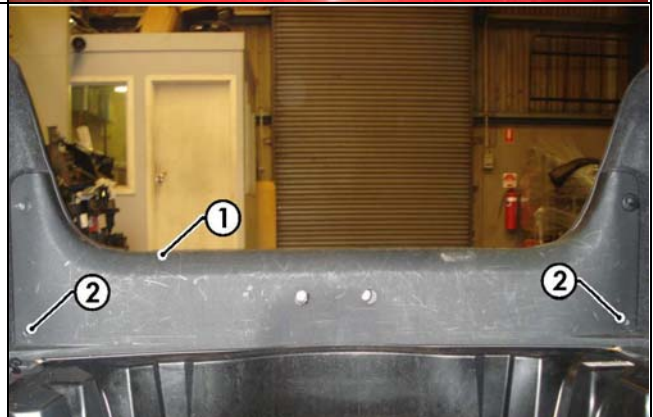

3. Remove the three clips (1) from the RHS luggage compartment trim and then peel open the trim (2).

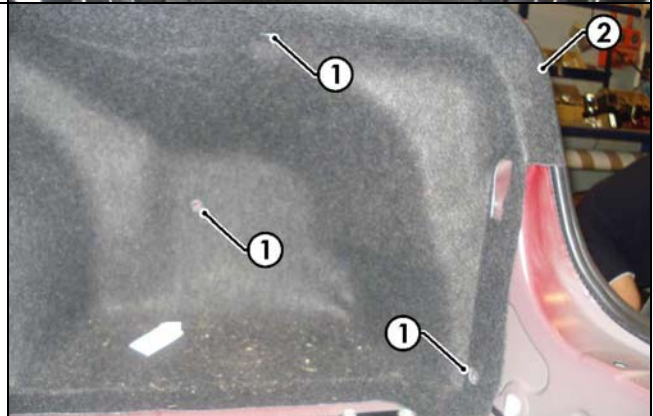

Issue Date 23-05-2011

Page 2

Part No: 100007-WL



Hayman Reese (Cequent)  
PO Box 4050, Dandenong South VIC 3164  
Phone 1800 812 017 Email [info@haymanreese.com.au](mailto:info@haymanreese.com.au)

[www.haymanreese.com.au](http://www.haymanreese.com.au)

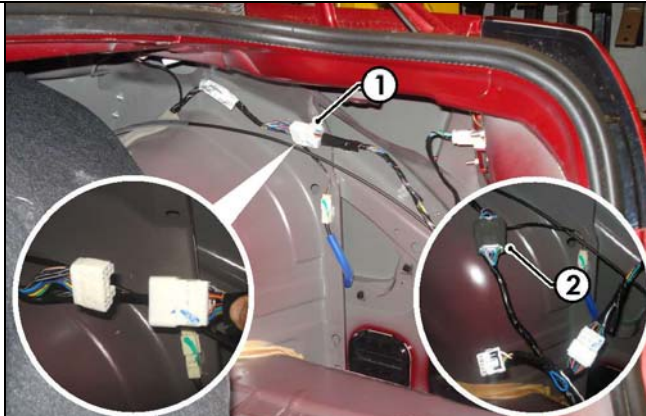

**HAYMAN REESE**  
**PART No: 100007-WL**  
**HOLDEN VE/WM COMMODORE SEDAN & WAGON**  
**INSTALLATION INSTRUCTIONS**

PLEASE ENSURE THAT INSTRUCTIONS ARE UNDERSTOOD PRIOR TO FITMENT

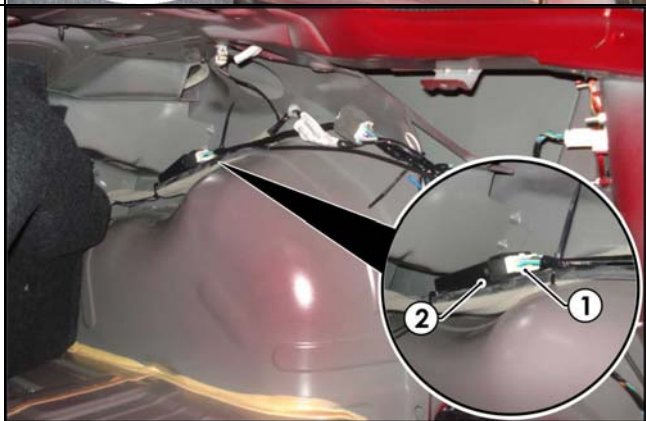
<p>4. Locate the 12-way tail light connectors. Disconnect the tail light connectors (1) and patch the Trailer Patch Harness (P/No: 100007-WL) connectors (2) in between the tail light connectors (1).</p>	
<p>5. Secure the Trailer Patch Harness ground ring terminal (1) using a tech screw (not supplied) (2) as shown.</p>	
<p>6. Connect the Trailer Patch Harness 12-way female ECU connector (1) into the ECU (04826) (2). 7. Apply double sided tape to the ECU (2) and adhere it to the vehicle sheet metal on the RHS of the luggage compartment wheel arch.</p>	

Issue Date 23-05-2011

Page 3

Part No: 100007-WL

Hayman Reese (Cequent)  
PO Box 4050, Dandenong South VIC 3164  
Phone 1800 812 017 Email [info@haymanreese.com.au](mailto:info@haymanreese.com.au)

[www.haymanreese.com.au](http://www.haymanreese.com.au)



**HAYMAN REESE**  
**PART No: 100007-WL**  
**HOLDEN VE/WM COMMODORE SEDAN & WAGON**  
**INSTALLATION INSTRUCTIONS**

PLEASE ENSURE THAT INSTRUCTIONS ARE UNDERSTOOD PRIOR TO FITMENT

8. Using a drill and a Ø31mm hole saw/step drill, drill a hole (1) into the spare tyre well as shown.



9. From outside of the vehicle, route the Tail Harness (tail length 1800mm) (1) into the bumper towbar cut out (2) and into the spare wheel well via the drilled out hole.



10. Mount the trailer socket (1) on to the towbar socket mounting plate using M4 fasteners (not supplied).

**NOTE: Image is for reference only. DO NOT mount onto the rear bumper fascia.**



Issue Date 23-05-2011

Page 4

Part No: 100007-WL

Hayman Reese (Cequent)  
PO Box 4050, Dandenong South VIC 3164  
Phone 1800 812 017 Email [info@haymanreese.com.au](mailto:info@haymanreese.com.au)

[www.haymanreese.com.au](http://www.haymanreese.com.au)



**HAYMAN REESE**  
**PART No: 100007-WL**  
**HOLDEN VE/WM COMMODORE SEDAN & WAGON**  
**INSTALLATION INSTRUCTIONS**

**PLEASE ENSURE THAT INSTRUCTIONS ARE UNDERSTOOD PRIOR TO FITMENT**

11. Inside the spare wheel well, route the Tail Harness all the way through and adjust the Tail Harness grommet (1) into position.
12. Secure the Tail Harness grommet into place with a cable tie (2) (not supplied).

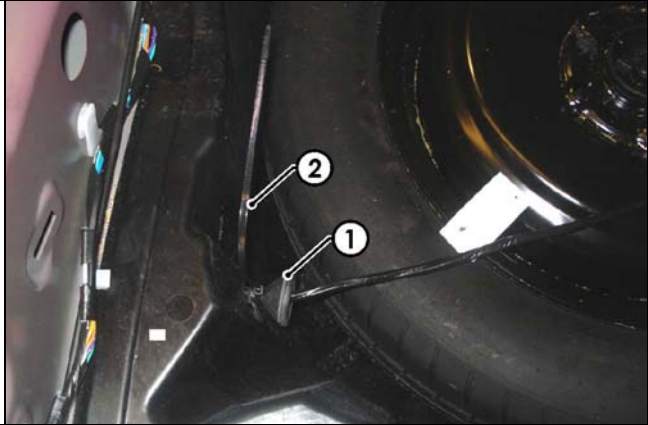

13. Connect the tail harness 8-way male connector (1) to the trailer harness mating 8-way female connector (2).

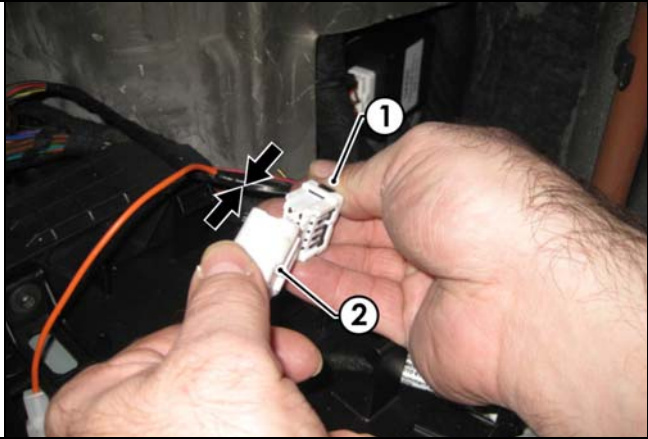

14. Test the trailer harness function using a light board or multimeter.
15. Secure all harnesses using cables ties (not supplied).
16. Re-fit all removed parts and secure all fasteners, ensuring there are no squeaks or rattles.
17. Place the instructions in the glove box after fitment.

Issue Date 23-05-2011

Page 5

Part No: 100007-WL

Hayman Reese (Cequent)  
PO Box 4050, Dandenong South VIC 3164  
Phone 1800 812 017 Email [info@haymanreese.com.au](mailto:info@haymanreese.com.au)

[www.haymanreese.com.au](http://www.haymanreese.com.au)



**HAYMAN REESE**  
**PART No: 100007-WL**  
**HOLDEN VE/WM COMMODORE SEDAN & WAGON**  
**INSTALLATION INSTRUCTIONS**

PLEASE ENSURE THAT INSTRUCTIONS ARE UNDERSTOOD PRIOR TO FITMENT

This section is for Wagon vehicles only.  
For Sedan vehicles please refer to Page 2.

18. In the luggage compartment, remove the floor carpet (1).
19. Remove the rear trim (2).



20. Remove the luggage compartment RHS rear side trim (1) by removing the cargo strap hooks and the lower clip (2).

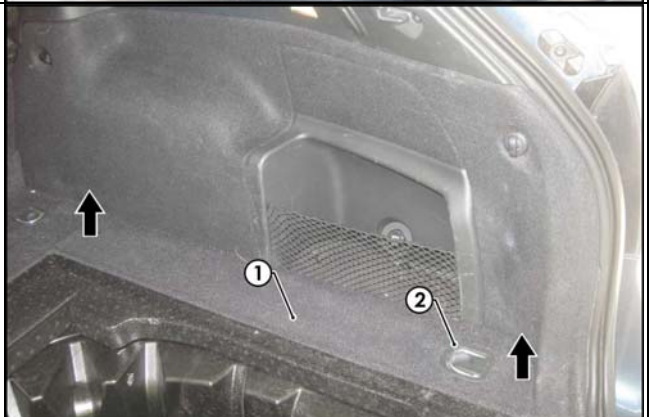

21. Remove the RHS foam spacer (1).

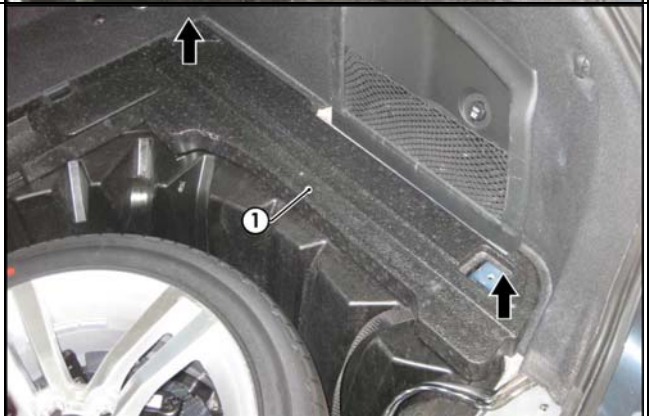

**HAYMAN REESE**  
**PART No: 100007-WL**  
**HOLDEN VE/WM COMMODORE SEDAN & WAGON**  
**INSTALLATION INSTRUCTIONS**

PLEASE ENSURE THAT INSTRUCTIONS ARE UNDERSTOOD PRIOR TO FITMENT

22. Dislodge the RHS rear side trim (1) by first removing any clips or fasteners (2)

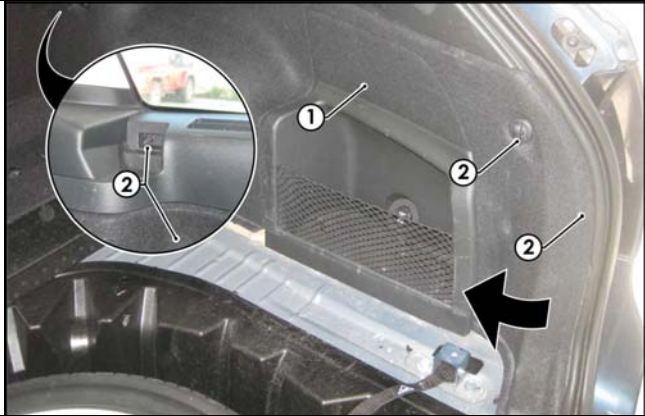

23. Locate the 12-way tail light connectors (1).  
24. Disconnect the tail light connectors (1) and patch the Trailer Patch Harness (P/No: 100007-WL) connectors (2) in between the tail light connectors (1).

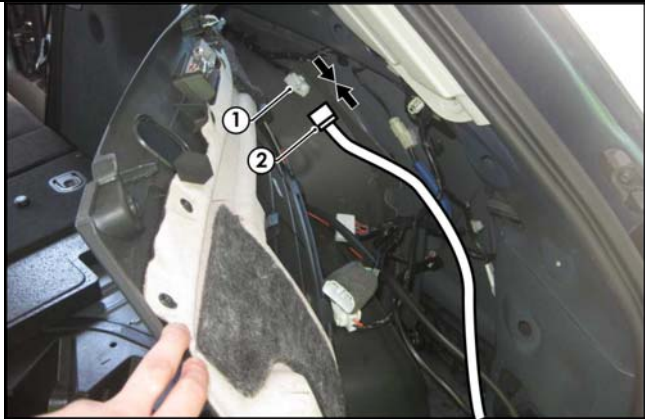

25. Secure the Trailer Patch Harness ground ring terminal (1) using a tech screw (2) as shown.



Issue Date 23-05-2011

Page 7

Part No: 100007-WL

Hayman Reese (Cequent)  
PO Box 4050, Dandenong South VIC 3164  
Phone 1800 812 017 Email [info@haymanreese.com.au](mailto:info@haymanreese.com.au)

[www.haymanreese.com.au](http://www.haymanreese.com.au)



**HAYMAN REESE**  
**PART No: 100007-WL**  
**HOLDEN VE/WM COMMODORE SEDAN & WAGON**  
**INSTALLATION INSTRUCTIONS**

PLEASE ENSURE THAT INSTRUCTIONS ARE UNDERSTOOD PRIOR TO FITMENT

26. Connect the Trailer Patch Harness 12-way female ECU connector (1) into the ECU (04826) (2).
27. Apply double sided tape to the ECU (2) and adhere it to the vehicle sheet metal on the RHS of the luggage compartment wheel arch.

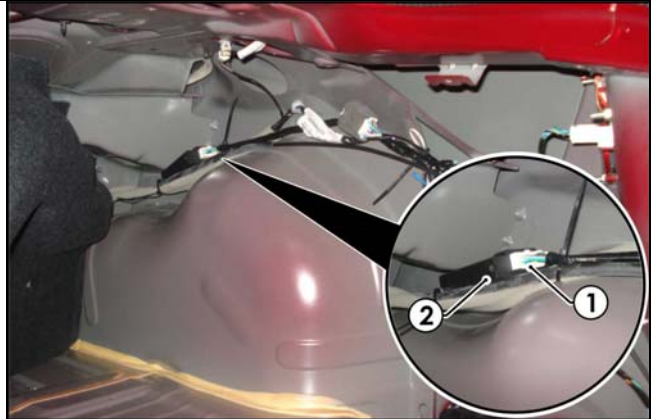

28. Using a drill and a Ø31mm hole saw/step drill bit, drill a hole (1) into the spare tyre well as shown.
29. File any rough or sharp edges and spray on rust inhibitor.



30. From outside of the vehicle, route the Tail Harness (tail length 1800mm) (1) into the bumper towbar cut out (2) and into the spare wheel well via the drilled out hole.



Issue Date 23-05-2011

Page 8

Part No: 100007-WL

Hayman Reese (Cequent)  
PO Box 4050, Dandenong South VIC 3164  
Phone 1800 812 017 Email [info@haymanreese.com.au](mailto:info@haymanreese.com.au)

[www.haymanreese.com.au](http://www.haymanreese.com.au)



**HAYMAN REESE**  
**PART No: 100007-WL**  
**HOLDEN VE/WM COMMODORE SEDAN & WAGON**  
**INSTALLATION INSTRUCTIONS**

PLEASE ENSURE THAT INSTRUCTIONS ARE UNDERSTOOD PRIOR TO FITMENT

31. Mount the trailer socket (1) onto the towbar socket mounting plate using M4 fasteners (not supplied).

**NOTE: Image is for reference only. DO NOT mount onto the rear bumper fascia.**



32. Inside the spare wheel well, route the Tail Harness all the way through and adjust the Tail Harness grommet (1) into position.  
33. Secure the Tail Harness grommet into place with a cable tie (2) (not supplied).

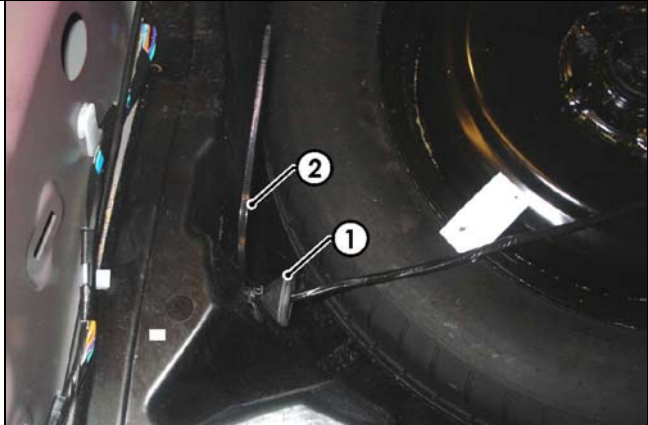

34. Connect the tail harness 8-way connector (1) to the trailer harness mating 8-way connector. (2).

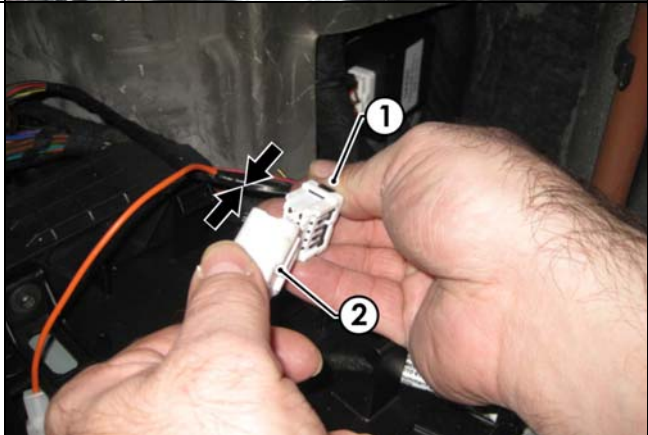

Issue Date 23-05-2011

Page 9

Part No: 100007-WL

Hayman Reese (Cequent)  
PO Box 4050, Dandenong South VIC 3164  
Phone 1800 812 017 Email [info@haymanreese.com.au](mailto:info@haymanreese.com.au)

[www.haymanreese.com.au](http://www.haymanreese.com.au)





**HAYMAN REESE**  
**PART No: 100007-WL**  
**HOLDEN VE/WM COMMODORE SEDAN & WAGON**  
**INSTALLATION INSTRUCTIONS**

PLEASE ENSURE THAT INSTRUCTIONS ARE UNDERSTOOD PRIOR TO FITMENT

- |   |  |
|---|--|
| <ul style="list-style-type: none"><li>35. Test the trailer harness function using a light board or multimeter.</li><li>36. Secure all harnesses using cables ties (not supplied).</li><li>37. Re-fit all removed parts and secure all fasteners, ensuring there are no squeaks or rattles.</li><li>38. Place the instructions in the glove box after fitment.</li></ul> |  |
|---|--|

Issue Date 23-05-2011

Page 10

Part No: 100007-WL

Hayman Reese (Cequent)  
PO Box 4050, Dandenong South VIC 3164  
Phone 1800 812 017 Email [info@haymanreese.com.au](mailto:info@haymanreese.com.au)

[www.haymanreese.com.au](http://www.haymanreese.com.au)

