

HAYMAN REESE

PART No: 03086W

KIA CERATO SEDAN 2014 - ON

INSTALLATION INSTRUCTIONS

PLEASE ENSURE THAT ALL INSTRUCTIONS ARE UNDERSTOOD PRIOR TO FITMENT
PLACE THESE INSTRUCTIONS IN THE VEHICLE'S GLOVEBOX AFTER INSTALLATION IS COMPLETED



Installation Time: Approx **120** Mins

Towbar Installation Instructions

Towbar capacity

KIA CERATO SEDAN 2014 - ON

Part Number 03086W

Max Towing Braked	1200 kg
Max Towing Unbraked	750 kg
Max Static Ball Load	75 kg

Hayman Reese (Cequent)
PO Box 4050, Dandenong South VIC 3164
Phone 1800 812 017 Email info@haymanreese.com.au

HAYMAN REESE

PART No: 03086W

KIA CERATO SEDAN 2014 - ON

INSTALLATION INSTRUCTIONS

PLEASE ENSURE THAT ALL INSTRUCTIONS ARE UNDERSTOOD PRIOR TO FITMENT
PLACE THESE INSTRUCTIONS IN THE VEHICLES'S GLOVEBOX AFTER INSTALLATION IS COMPLETED

Warning:

1. Do not, drill, cut, weld or otherwise modify the towbar.
2. If you are using electric welding on a motor vehicle, **always** check that the vehicle is not equipped with electronic engine or instrument management equipment. Failure to do so could **destroy** any onboard computers. If in doubt, check with the vehicle's manufacturer.
3. If TBM is used in inverted position tow ball may make contact with rear tailgate when lowered, which could cause damage.

General:

1. Ensure all hardware items have been included refer to assembly diagram.
2. It is recommended that the instructions are read through and completely understood before making any attempt to fit this product.
3. Be wary of any changes to vehicle designs or other accessories that may conflict with the installation of this product.
4. Before drilling ensure that the area is clear of fuel, electrical & other components.
5. All holes drilled into the body panels shall have all burrs & swarf removed then coated with a suitable rust preventative paint.
6. The high tensile fasteners supplied with this product were used to achieve the specified rating. If replacement is required ensure that fasteners of the same rating & quality are used. Contact an authorised **Hayman Reese** dealer if further information is required.
7. Ensure that all hardware is fastened to torque list below check fasteners on regular basis.
8. Towbar load rating sticker provided with this product shall be conspicuously located on inside rear end of the driver's door. **(See diagram below).**
9. Hayman Reese recommends that you check your tow ball to ensure that it complies with the Australian standards **AS 4177.2**.
10. **PLEASE NOTE:** It is advised to remove your lug or tbn when not actually towing so as to produce a clear view of the vehicles registration plate if obscured, and to also provide maximum available departure angle.
11. Pull Pin must be fit in down position.

Tow bar Maintenance and Care.

Hayman Reese recommends that bolt torque's, as listed below, are routinely and regularly inspected and checked for correct tension. Replace any worn or defective parts.

We recommended to remove Tow Ball Mounts (TBM's, tongues or lugs) when not being used for any considerable length of time.

So as to avoid injury, when not towing it is suggested that the tongue, Pull Pin and R-clip are removed then stored in a safe, clean and dry place, away from excessive moisture.

Hitch Pull Pins and spring "R" clips are regularly checked for proper installation. Replace any worn or defective parts.

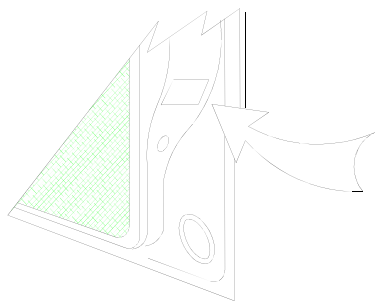

Place load rating sticker
inside driver's door here

RECOMMENDED ASSEMBLY TORQUE LISTING

Diameter Grade 8.8 Bolt

M6	9.5 Nm
M8	21.7 Nm
M10	43.4 Nm
M12	77.3 Nm
M14	146 Nm
M16	189.8 Nm

FOR TOWING PURPOSES ONLY

For towing capacity details please refer to vehicle owner's manual or to the manufacturer. Overloading can void your warranties.

HAYMAN REESE

PART No: 03086W

KIA CERATO SEDAN 2014 - ON

INSTALLATION INSTRUCTIONS

PLEASE ENSURE THAT ALL INSTRUCTIONS ARE UNDERSTOOD PRIOR TO FITMENT
PLACE THESE INSTRUCTIONS IN THE VEHICLES'S GLOVEBOX AFTER INSTALLATION IS COMPLETED

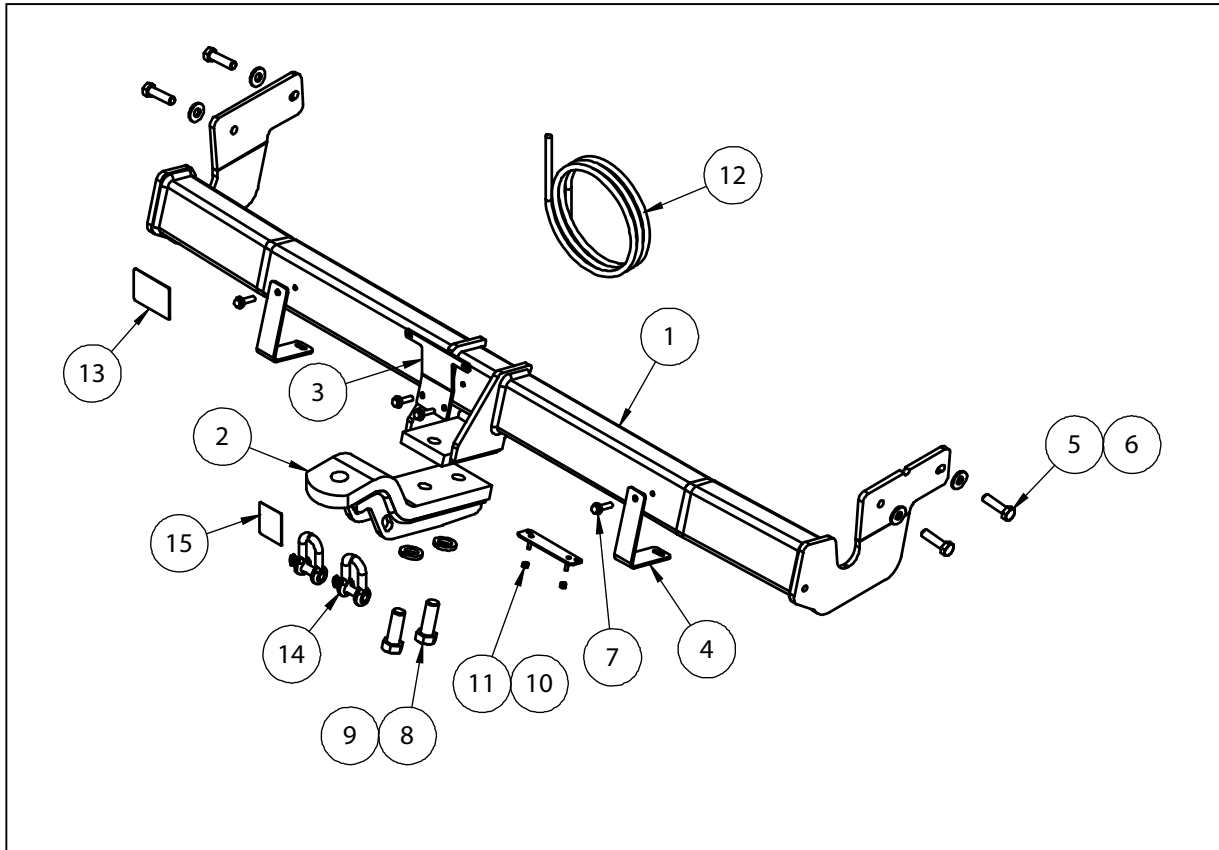

QTY.	DESCRIPTION	ITEM NO.
1	KIA CERATO WELDED ASSY	1
1	TONGUE ASSEMBLY	2
1	SENSOR TAB	3
2	BUMPER TAB	4
4	SET SCREW HX HD M10x45x1.25P	5
4	WASHER FT M10x25.4x3	6
4	TEK SCREW 14-20 HEX HD 22mm	7
2	BOLT M16x45 2.0P	8
2	SPRING WASHER M16x5x3.5	9
1	PLUG BRACKET	10
2	NUT NYLOC M4-0.7 Z/P	11
1	WIRING LOOM	12
1	ACRYLIC COMPLIANCE PLATE	13
2	D SHACKLE	14
1	H.R STICKER	15

HAYMAN REESE

PART No: 03086W

KIA CERATO SEDAN 2014 - ON

INSTALLATION INSTRUCTIONS

PLEASE ENSURE THAT ALL INSTRUCTIONS ARE UNDERSTOOD PRIOR TO FITMENT
PLACE THESE INSTRUCTIONS IN THE VEHICLES'S GLOVEBOX AFTER INSTALLATION IS COMPLETED

1. Remove 2x Screws located inside the rear wheel well.

Repeat for opposite side of vehicle.

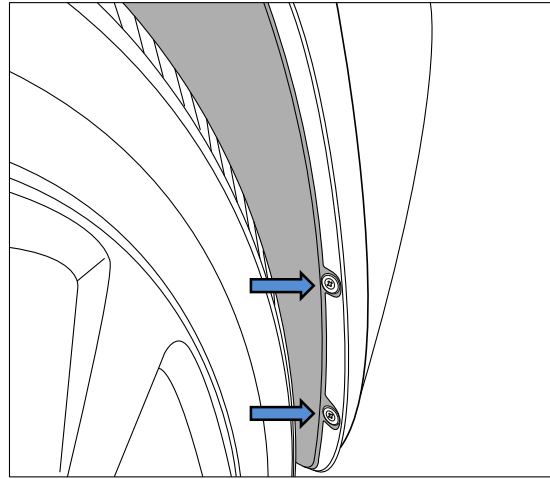

2. Remove Screw securing upper Bumper lip, located in rear wheel well above Screws removed in step 1.

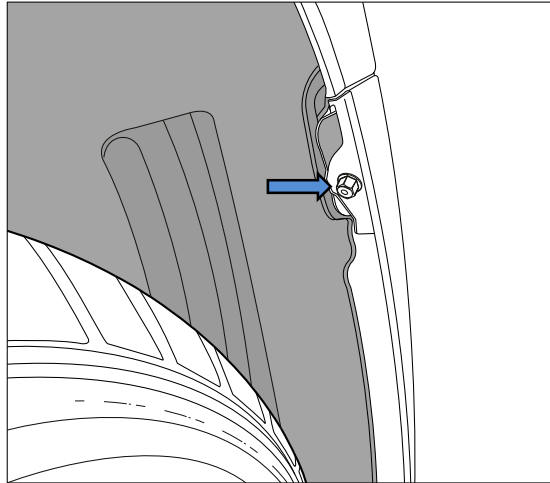

3. Remove 3x Scrivets located on the underside of Bumper, behind the rear RHS tyre.

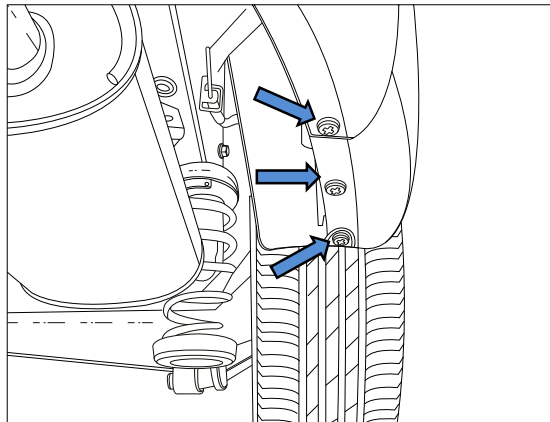

INSTALLATION INSTRUCTIONS

**PLEASE ENSURE THAT ALL INSTRUCTIONS ARE UNDERSTOOD PRIOR TO FITMENT
PLACE THESE INSTRUCTIONS IN THE VEHICLES'S GLOVEBOX AFTER INSTALLATION IS COMPLETED**

4. Detach lower mudguard from vehicle body by removing scrivets and screws securing flap.
5. Remove 2x Scrivets from behind LHS rear tyre in similar manner to step 3.

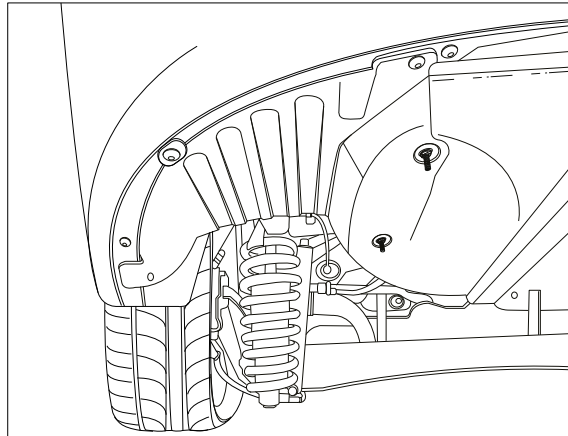

6. Remove access panels inside vehicle boot lid cavity.

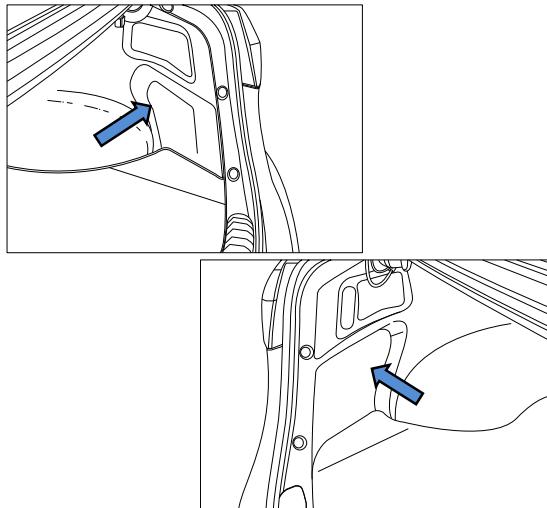

7. From inside the newly exposed section, remove 4x Nuts securing tail light to chassis.

Disconnect white plug and remove tail light by pulling rearwards of vehicle.

Repeat for opposite side of vehicle.

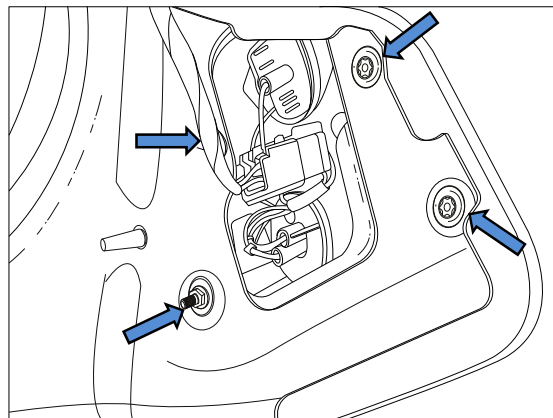

HAYMAN REESE

PART No: 03086W

KIA CERATO SEDAN 2014 - ON

INSTALLATION INSTRUCTIONS

PLEASE ENSURE THAT ALL INSTRUCTIONS ARE UNDERSTOOD PRIOR TO FITMENT
PLACE THESE INSTRUCTIONS IN THE VEHICLES'S GLOVEBOX AFTER INSTALLATION IS COMPLETED

8. In newly exposed section after removing tail light, remove 1x Scrivet and 1x Screw.

Repeat for opposite side of vehicle.

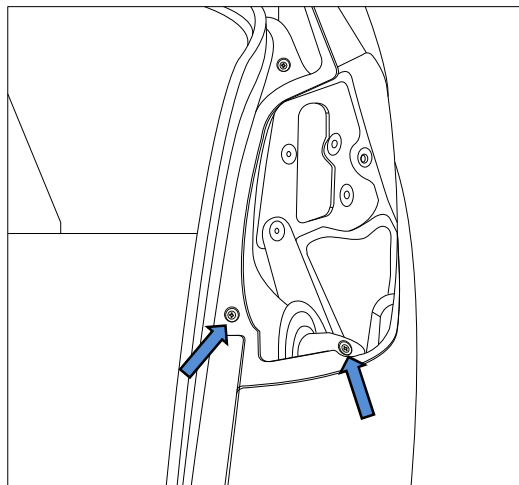

9. From underneath vehicle, remove 4x Screws (2 per side) securing Bumper assembly to rear vehicle panel.

Carefully peel away bumper from vehicle and disconnect any rear parking sensors and keyless entry sensors if supplied.

Note: 2 people are required for task.

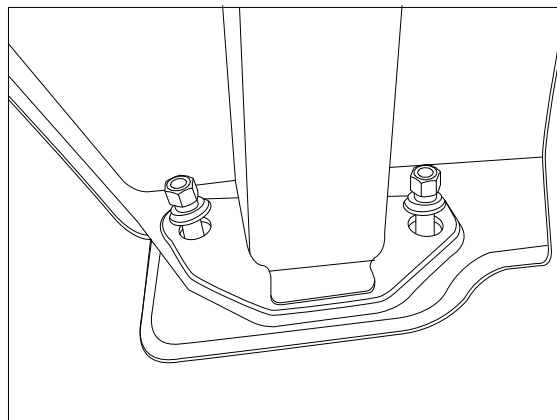

10. Remove 5x Scrivets securing rear impact beam to inside of rear bumper assembly.

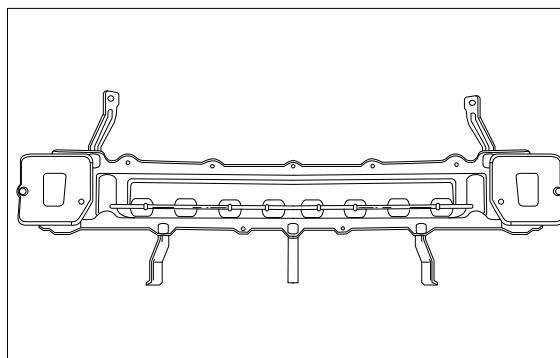

HAYMAN REESE

PART No: 03086W

KIA CERATO SEDAN 2014 - ON

INSTALLATION INSTRUCTIONS

PLEASE ENSURE THAT ALL INSTRUCTIONS ARE UNDERSTOOD PRIOR TO FITMENT
PLACE THESE INSTRUCTIONS IN THE VEHICLES'S GLOVEBOX AFTER INSTALLATION IS COMPLETED

11. Mount Towbar assembly to vehicle, secure with M10 Bolts supplied and torque to 68Nm.

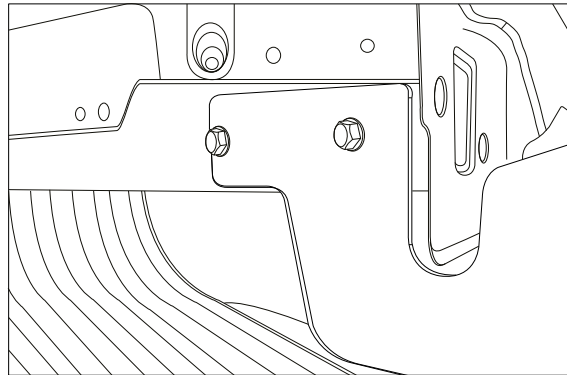

12. Mount supplied brackets to outermost holes on Towbar crosstube using supplied self-tapping Screws to allow for connection to bumper upon reassembly.
13. If vehicle is mounted with a keyless entry sensor, install onto supplied plate and mount with self-tapping screws to central section of Towbar.

CAUTION

Do not overtighten screws as they may break and render installation onto Towbar difficult.

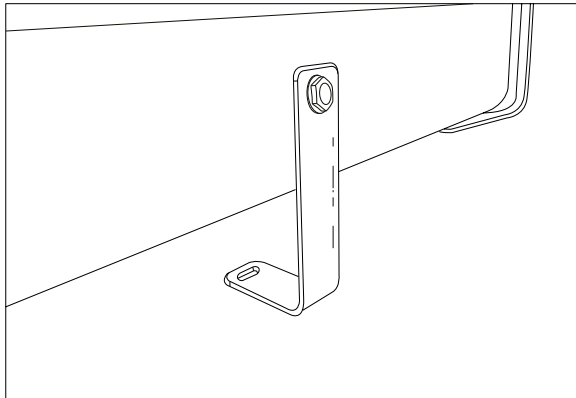

14. Perform a cut in the Bumper, central to Towbar centre section.

Cut must be 100mm wide and 150mm long, starting from lower lip.

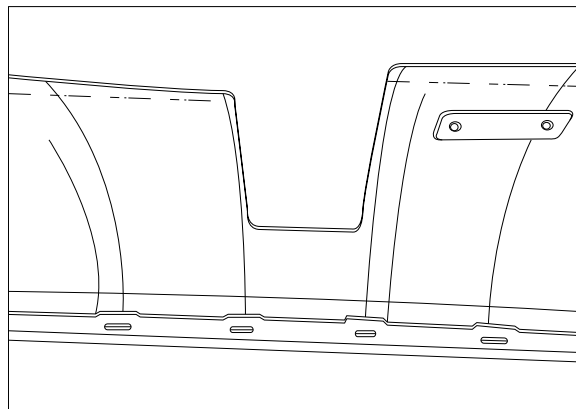

HAYMAN REESE

PART No: 03086W

KIA CERATO SEDAN 2014 - ON

INSTALLATION INSTRUCTIONS

PLEASE ENSURE THAT ALL INSTRUCTIONS ARE UNDERSTOOD PRIOR TO FITMENT
PLACE THESE INSTRUCTIONS IN THE VEHICLES'S GLOVEBOX AFTER INSTALLATION IS COMPLETED

15. Reinstall bumper following steps 1 – 8 in reverse.

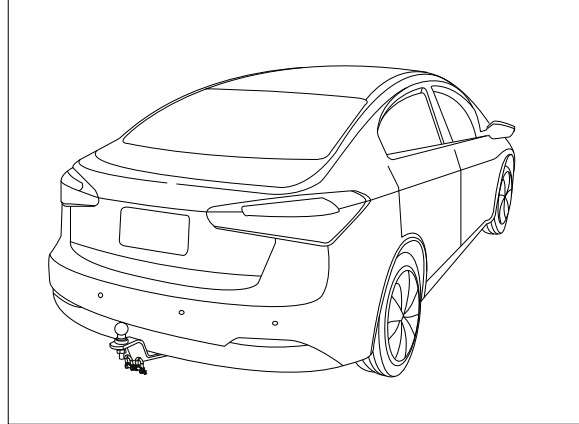

HAYMAN REESE
PART No: 101234-WL
KIA CERATO

INSTALLATION INSTRUCTIONS

PLEASE ENSURE THAT INSTRUCTIONS ARE UNDERSTOOD PRIOR TO FITMENT

Wiring Loom Installation Instructions

KIT CERATO SERIES
Part No: 101234-WL

Tail Harness Length Required: 1200mm

Wiring Loom Installation Time: Approx 30 Mins

Important



Due to possible vehicle variations, always confirm any noted vehicle colour wires with a multi-meter to ensure the correct function is identified before soldering or scotch locking.

Issue Date 26-11-14

Page 1

Hayman Reese (Cequent)
PO Box 4050, Dandenong South VIC 3164
Phone 1800 812 017 Email info@haymanreese.com.au

www.haymanreese.com.au



HAYMAN REESE
PART No: 101234-WL
KIA CERATO

INSTALLATION INSTRUCTIONS

PLEASE ENSURE THAT INSTRUCTIONS ARE UNDERSTOOD PRIOR TO FITMENT

1. Inside the luggage compartment, remove the floor carpet (1).

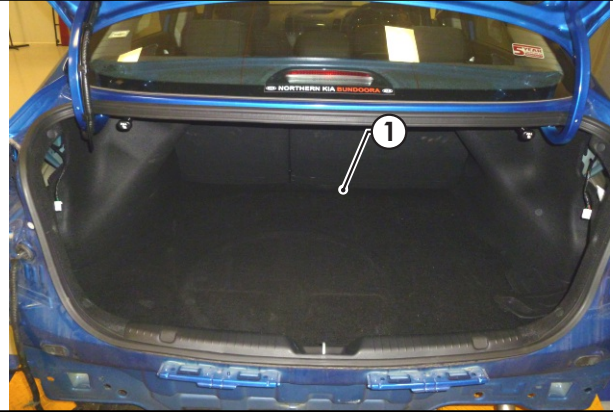

2. Remove the rear trim (1) by removing the three fasteners (2).

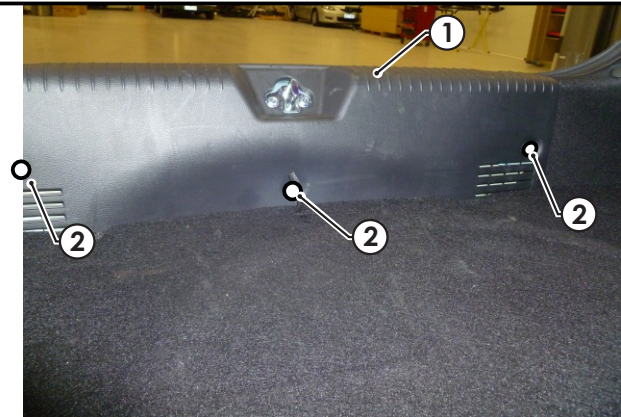

3. Remove the three fasteners (1) and one screw (2) from the LHS luggage compartment trim (3) to dislodge enough of the trim
Repeat for the RHS.

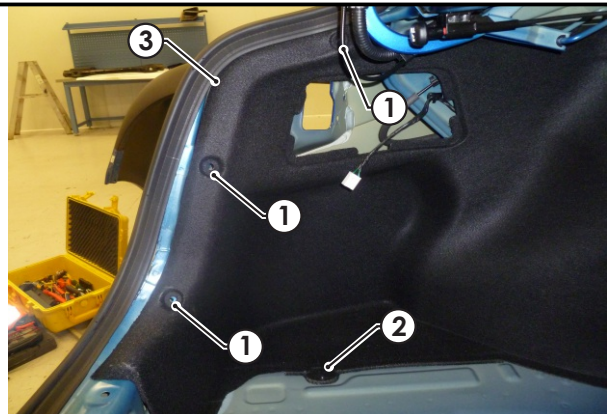

Issue Date 26-11-14

Page 2

Hayman Reese (Cequent)
PO Box 4050, Dandenong South VIC 3164
Phone 1800 812 017 Email info@haymanreese.com.au

HAYMAN REESE

PART No: 101234-WL

KIA CERATO

INSTALLATION INSTRUCTIONS

PLEASE ENSURE THAT INSTRUCTIONS ARE UNDERSTOOD PRIOR TO FITMENT

4. At the LHS rear quarter, near the vent, locate and remove the vehicle grommet (1). If the grommet hole is occupied, choose a suitable location (2) next to the existing grommet (1) and drill a Ø30mm hole. Apply rust inhibitor after drilling (not supplied).

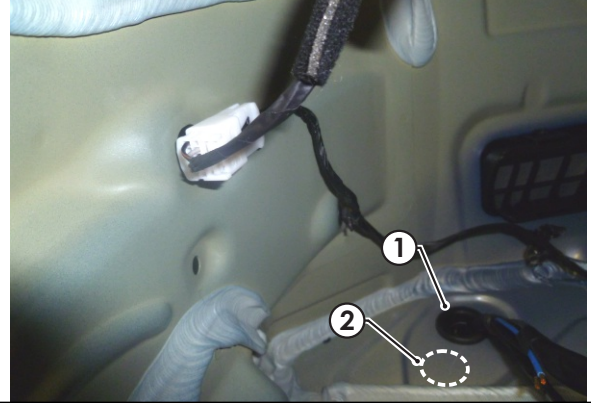

5. Disconnect the LHS tail light connectors (1) and connect the trailer patch (P/No: 101234-WL) LHS branch connectors (2) in between.

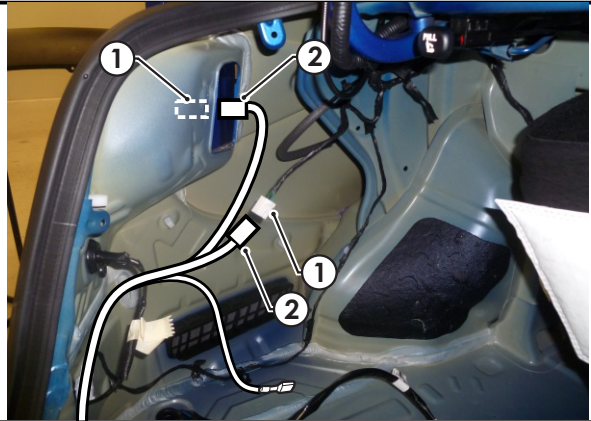

6. Locate the vehicle harness next to the boot hinge and carefully expose the vehicle harness wires.
7. Secure the supplied scotch lock (1) onto the vehicle harness GREY/WHITE reverse wire (2) and connect the trailer patch BLACK wire terminal (3) to the scotch lock (1).

Vehicle Wire	Trailer Patch	Function
GREY/WHITE	BLACK	REVERSE

8. Secure the trailer patch ground ring terminal (4) to a suitable location on the vehicle sheet metal using a tek screw (not supplied).

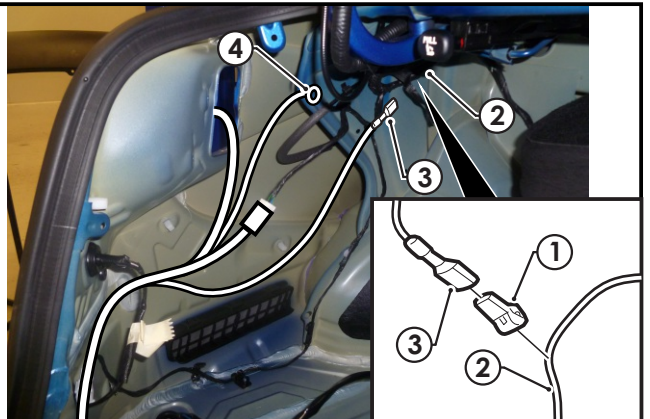

Issue Date 26-11-14

Page 3

Hayman Reese (Cequent)
 PO Box 4050, Dandenong South VIC 3164
 Phone 1800 812 017 Email info@haymanreese.com.au

HAYMAN REESE
PART No: 101234-WL
KIA CERATO

INSTALLATION INSTRUCTIONS

PLEASE ENSURE THAT INSTRUCTIONS ARE UNDERSTOOD PRIOR TO FITMENT

9. Route the trailer patch RHS branch across the rear of the vehicle towards the RHS tail lights. Disconnect the RHS tail light connectors (1) and connect the trailer patch (P/No: 101234-WL) LHS branch connectors (2) in between.

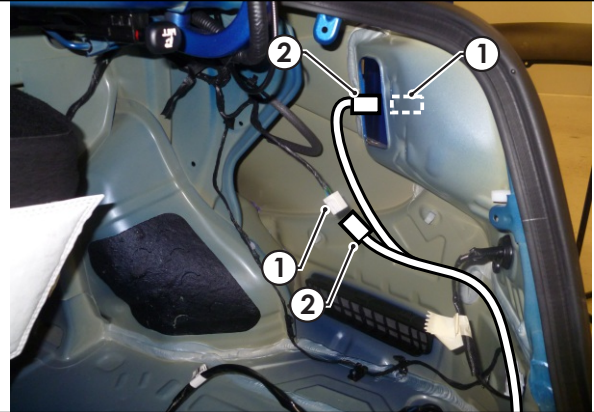

10. At the rear exterior of the vehicle, mount the tail harness socket (1) to the towbar mounting bracket using M4 fasteners (not supplied).
11. Route the tail harness (tail length: 1200mm) (2) across the LHS and up into the drilled out (or existing) grommet hole (3). Adjust the trailer patch harness grommet so that it is seated correctly and cable tie (not supplied) in place.



12. Connect the tail harness 8-way connector (1) to the trailer patch 8-way mating connector (2).

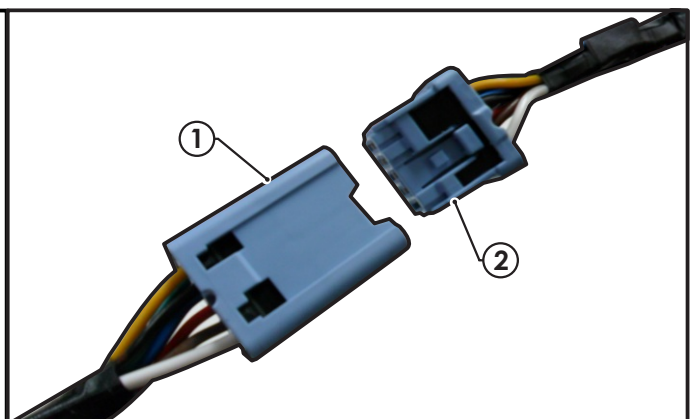

Issue Date 26-11-14

Page 4

Hayman Reese (Cequent)
PO Box 4050, Dandenong South VIC 3164
Phone 1800 812 017 Email info@haymanreese.com.au

HAYMAN REESE
PART No: 101234-WL
KIA CERATO

INSTALLATION INSTRUCTIONS

PLEASE ENSURE THAT INSTRUCTIONS ARE UNDERSTOOD PRIOR TO FITMENT

13. Test the body harness using a light board or multimeter.
14. Secure all harnesses using cable ties (not supplied).
15. Re-fit all removed parts and secure all fasteners, ensuring there are no squeaks or rattles.
16. Place the instructions in the glove box after fitment.

Issue Date 26-11-14

Page 5

Hayman Reese (Cequent)
PO Box 4050, Dandenong South VIC 3164
Phone 1800 812 017 Email info@haymanreese.com.au

www.haymanreese.com.au

